



GT15



3G/ 4G Wireless Data Logger



PRODUCT FEATURES

- Built-in 5 years battery lifespan
- Acquire flow & pressure data simultaneously
- Robust IP68 rated housing
- User-defined logging and transmission intervals
- Alarm setting of high-low flow/pressure limit
- Data logging of totalizer, forward/reverse flow, pressure, and signal strength
- External battery pack, mains electricity, and solar power are available
- Reed switch to check smart functions on sites

APPLICATIONS

- District / zone flow and pressure monitoring
- Commercial and industrial monitoring
- 3G / 4G communications

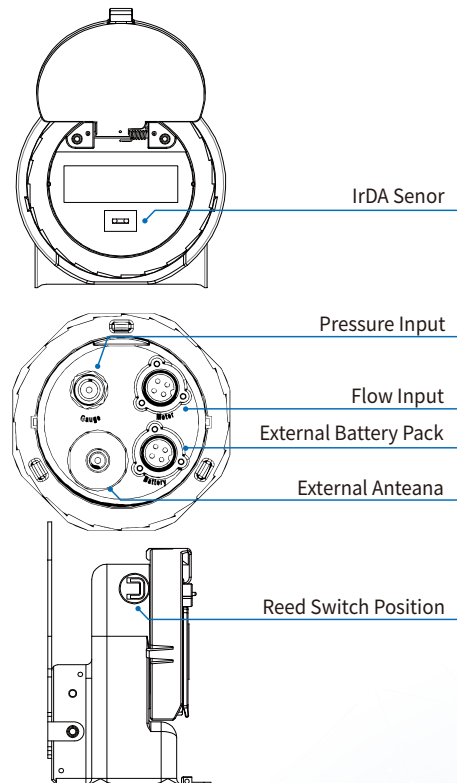
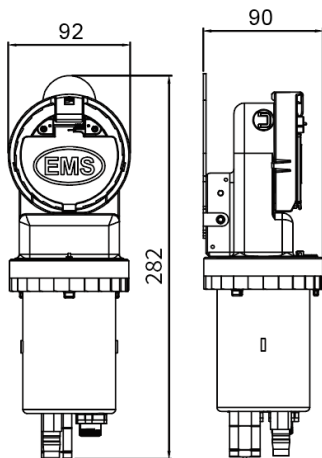

	Length	Width	Height	Weight
GT15	92 mm	90 mm	282 mm	1070 g



ENERGY MANAGEMENT SYSTEM CO., LTD.

TEL : +886-6-5050207
WEB : www.ems.com.tw/en/



TECHNICAL SPECIFICATIONS

Parameter		Specifications
Operating temperature		-25°C~70°C
Protection degree		IP68
Power supply	Built-in battery	5 years lithium battery (daily transmission)
	External power	1~3 years external battery pack (10 mins transmission) Mains electricity Solar power

CONNECTIONS

Parameter	Specifications
Flow	EMS digital water meter / 2 sets pulse input (optional)
Pressure	Built-in pressure gauge

COMMUNICATIONS

Parameter	Specifications
4G	FDD LTE : B1 / B3 / B5 / B7 / B8 / B20/ B28
3G	UMTS : B1 / B3 / B8
2G	GSM : 850 / 900 / 1800 / 1900 MHz
SIM	Standard SIM (Mini SIM)
External antenna	3 meters
Site	Configured by IrDA reader
Remote	Wireless configuration by 3G / 4G

LOGGING

Parameter	Specifications
Logging Capacity	Flow up to 800,000 Pressure up to 2,000,000 Flow & Pressure up to 570,000
Transmission	Logging frequency from 1 Sec. to 1440 Mins. Transmission frequency from 10 Mins. to 1440 Mins.

COMMUNICATIONS NETWORK

